

ST-Series

Sealed Toggle Switches

PRODUCT WEBPAGE

request sample, configure part, watch video

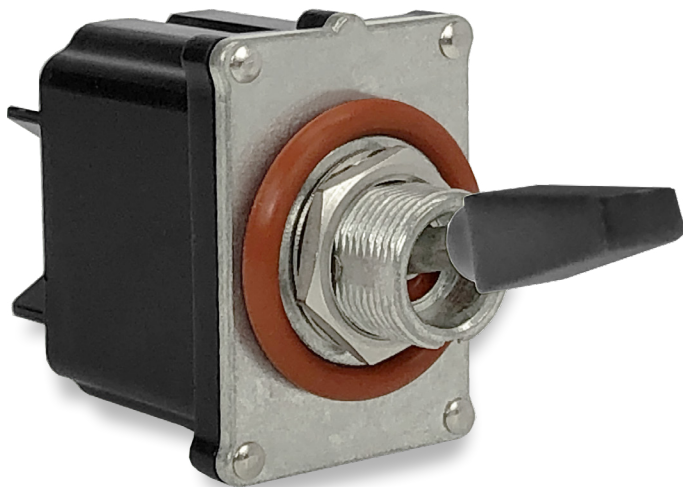
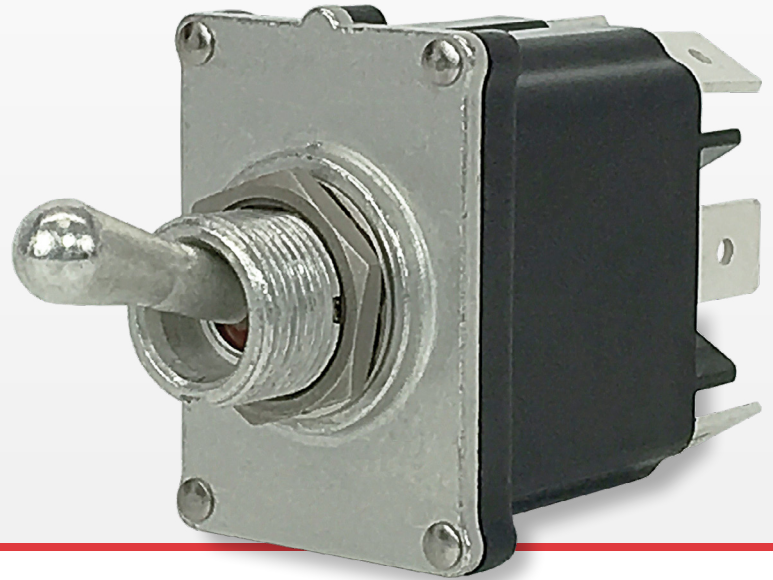

Designed to conform to MIL-DTL-3950G requirements for environmentally sealed toggle switches, and compliant to UL 60079-15 standard for use in explosive gas atmospheres. The ST-Series is fully sealed to IP68, including below the panel and features innovative design and performance principles sure to withstand the most demanding applications.

1-2
Poles

10-16
Amps

125, 250
VAC

12-24
VDC

Typical Applications

- Off-Highway
- Commercial Food
- Marine
- Armored Vehicles
- Military
- Applications requiring stringent sealing

Design Features

PINNED ACTUATOR / BUSHING

Keeps toggle or paddle firmly in place and prevents rotation

BRASS ROLLER PIN

Provides rolling metal on metal actuation for maximum endurance

BASE SEAL CHANNEL

Perfectly fits the toggle assembly seal decreasing the dependence on clamping forces and rivets

TERMINAL BARRIERS

Comply with UL-61058-1 electrical spacing requirements

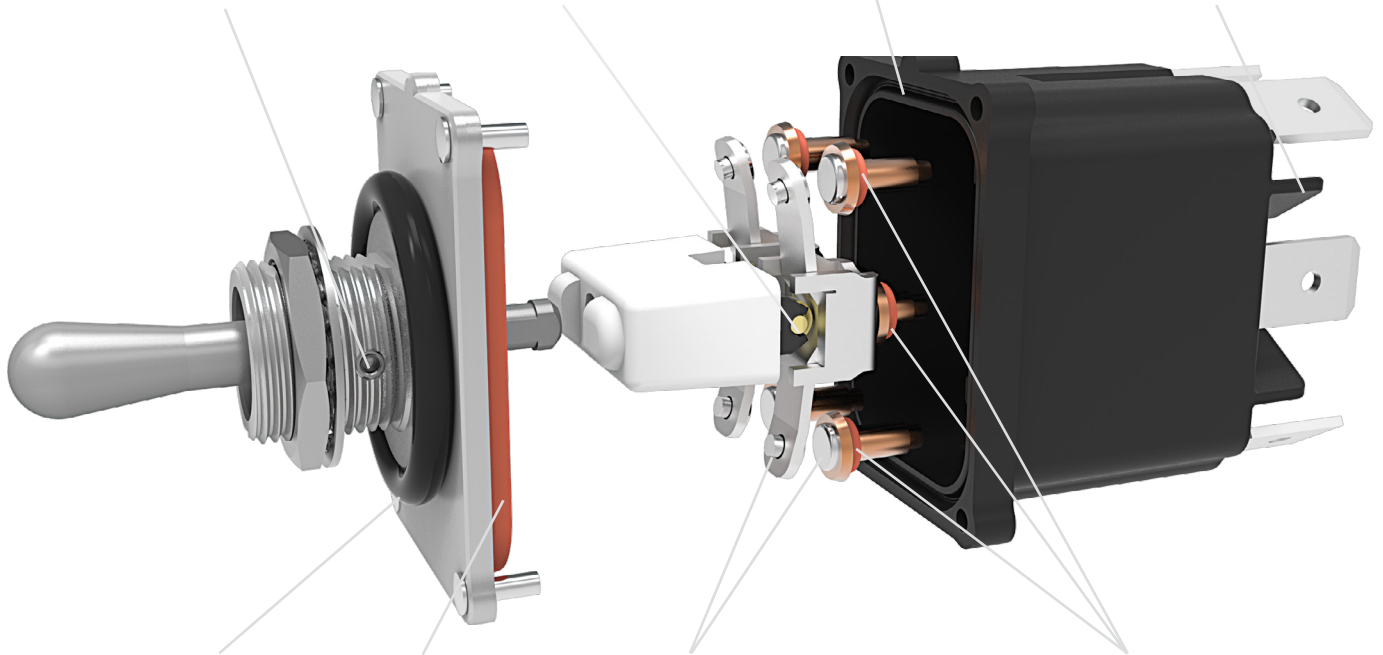

OPTIONAL O-RING

Assures additional under panel sealing protection

BUSHING/TOGGLE SEAL

Composed of dynamic silicone material that bonds to the metal toggle, pin, and bushing

RIVETS

High purity copper composite and silver alloy materials handle various electrical loads and maintain low contact resistance

TERMINAL SEALS

Assure a secure seal at extreme temperatures. Eliminates potential for separated joints associated with insert molded constructions

Tech Specs

Electrical

| | |
|----------------------------|---|
| Contact Rating | 10A 250VAC, 15A 125VAC, 16A 12/24VDC |
| Dielectric Strength | MIL-STD-202G, Method 301 (1500 Volts RMS) |
| Insulation Resistance | MIL-STD-202G, Method 302 (50 MegOhms, 500 VDC) |
| Initial Contact Resistance | MIL-STD-202G, Method 307 (10 milliOhms max.) |
| Insulation Resistance | Overload: MIL-DTL-3950G, Section 4.8.11.1 Electrical Endurance and Temperature: UL 61058-1 Momentary circuits: 25,000 operations, minimum. Maintained circuits: 50,000 operations, minimum. |
| Initial Contact Resistance | UL-1500 Ignition-Protection Test for Marine Products |
| Ignition Protection | Up to 100,000 cycles, circuit and load dependent |
| Explosion Protection | UL 60079-15 Electrical Apparatus for Explosive Gas Atmospheres |
| Contacts | Silver / Nickel Alloy |
| Terminals | Brass or Copper / silver plated. Tab Terminal: ¼" quick-connect Screw Terminal: #6-32 brass screw and cage clamp MIL-STD-202G, Method 211 Test Condition A, and B: 25 lb. pull test, two terminal bends. |

Agency Approvals

UL and cUL
Reference: UL 61058-1 and CAN/CSA-C22.2 No. 61058-1-09, Switches for Appliances - Part 1: General Requirements. Certificate number 20181012-E7560.
UL 1500 Ignition-Protection.
UL 60079-15 Electrical Apparatus for Explosive Gas Atmospheres.

Environmental

| | | | | | | | | | | | |
|-------------------------------|---|----------|---------------|----------|------|-----------------|--------------|------------------|--------------|-------------|------|
| Temperature | Operating: -40°C to +85°C Storage: -65°C to +85°C | | | | | | | | | | |
| Vibration | MIL-STD-202G: Method 204D, Test Condition A (10 G peak, Harmonic, 10Hz to 500Hz sweeps, 9 hours total). | | | | | | | | | | |
| Shock | MIL-STD-202G: Method 213B, Test Condition K (30 G, half sine) | | | | | | | | | | |
| Sealing | IP68, for above and below-panel components of actual switch only. | | | | | | | | | | |
| Salt Atmosphere | MIL-STD-202G, Method 101, Test Condition A (96 hrs) | | | | | | | | | | |
| Thermal Shock | MIL-STD-202G, Method 107, Test Condition A (five cycles in air: -55°C, +25°C, +125°C, +25°C) | | | | | | | | | | |
| Moisture Resistance, Humidity | MIL-STD-202G, Method 106 (ten 24-hour stepped cycles) | | | | | | | | | | |
| Chemical Resistance | No permanent loss of function, obvious loss of sealing, distortion, softening, embrittlement, discoloration or corrosion after being brushed for 10 minutes, wetting all exposed surfaces. Relevant chemical compatibility documentation may be used in place of testing. <table border="1" data-bbox="1084 1003 1469 1129"> <tr> <td>Chemical</td> <td>Concentration</td> </tr> <tr> <td>Gasoline</td> <td>100%</td> </tr> <tr> <td>Ethylene Glycol</td> <td>50% in water</td> </tr> <tr> <td>Ethanol/Methanol</td> <td>10% in water</td> </tr> <tr> <td>Diesel Fuel</td> <td>100%</td> </tr> </table> | Chemical | Concentration | Gasoline | 100% | Ethylene Glycol | 50% in water | Ethanol/Methanol | 10% in water | Diesel Fuel | 100% |
| Chemical | Concentration | | | | | | | | | | |
| Gasoline | 100% | | | | | | | | | | |
| Ethylene Glycol | 50% in water | | | | | | | | | | |
| Ethanol/Methanol | 10% in water | | | | | | | | | | |
| Diesel Fuel | 100% | | | | | | | | | | |

Physical

| | |
|-------------------------------|---|
| Function, Operation, Circuits | Single Pole/ Double Pole with Circuits Single Throw/ Double Throw, Two/Three position, Maintain/ Momentary circuits |
| Toggle | Tin plated brass bat or tall bat |
| Paddle | Acetal, UV stabilized yellow, red, white and black. |
| Mechanism Actuator | Polyester PBT, UL94-V0 and fungus resistant per MIL-STD- 810G, Section 508.6 |
| Internal Seals | Silicone per A-A-59588-1A. |
| Mounting, Hardware | 15/32"-32 UNS-2A threaded bushing with a keyway. A single nut and lock washer are supplied unassembled. |
| Bushing/Top Plate | Zinc/aluminum die cast, with tin plating. |
| Base | Polyester PBT, UL94-V0 and fungus resistant per MIL-STD- 810G, Section 508.6 |
| Actuation Force | Initial Actuation Forces ± 0.3 lb (for 2-Pole circuits, short bat) |
| Angular Movement | 14.5 degrees, each side of center |

Ordering Scheme

Sample Part Number **ST A 2 E 1 - 53**

Selection 1 2 3 4 5 6

1. SERIES

ST Sealed Toggle

2. CIRCUIT

| | 2 & 3, 5 & 6 Connected Terminals | | 1 & 2, 4 & 5 |
|-------------------------------|----------------------------------|-------|--------------|
| Position: | 1 | 2 | 3 |
| A | ON | NONE | OFF |
| B | (ON) | NONE | OFF |
| C | ON | NONE | (OFF) |
| D | ON | NONE | ON |
| F ⁶ | ON | NONE | (ON) |
| J | ON | OFF | ON |
| K | ON | OFF | (ON) |
| L | (ON) | OFF | (ON) |
| Special Circuits ⁶ | | | |
| E ^{2,3} | 5 & 6 | 5 & 3 | 5 & 1 |
| G ^{2,4} | 2 & 3, 5 & 6 | 2 & 3 | OFF |
| M ^{2,4} | (2 & 3, 5 & 6) | 2 & 3 | OFF |

3. POLES

- 1** Single pole using terminals 1, 2 & 3
- 2** Double pole using terminals 1, 2, 3, 4, 5 & 6

Notes:

- 1 Standard hardware is (1) inner tooth lock washer and (1) hex nut bulk.
- 2 Available only with 2 pole option in selection box # 3.
- 3 External customer supplied jumper required between terminals 2 & 4 to get SP ON-ON-ON circuit.
- 4 Available with termination B and E only.
- 5 Available with special circuit G and M only.
- 6 Not available with rating 5.
- 7 Available with termination 1 and 4 only.

[Configure Complete Part Number >](#)

[Browse Standard Parts >](#)

4. RATING

- 4** 10A 250VAC; 15A 125VAC
- 5**⁷ 10A 250VAC; 15A 125VAC (UL, cUL Recognized)
- E** 16A, 12/24VDC

5. TERMINATION

- 1** .250 (6.4mm) TAB (QC)
- 4** Screw with Cage Clamps
- B**⁵ .250 (6.4mm) TAB (QC). Jumper T2 to T5.
No terminal at T5
- E**⁵ Screw with Cage Clamps. Jumper T2 to T5.
No terminal at T5

6. ACTUATOR STYLE

TOGGLE (SEALED METAL)

| Without Panel Seal | With Panel Seal (Bulk) | Toggle Color | Toggle Length | Bushing Length |
|--------------------|------------------------|--------------|---------------|----------------|
| 53 | 58 | Dull Nickel | .561 | .385 |
| 73 | 78 | Dull Nickel | .687 | .385 |

PADDLE (SEALED PLASTIC)

| Without Panel Seal | With Panel Seal (Bulk) | Paddle Color | Paddle Length | Bushing Length |
|--------------------|------------------------|--------------|---------------|----------------|
| B3 | B8 | Black | .880 | .385 |
| W3 | W8 | White | .880 | .385 |
| R3 | R8 | Red | .880 | .385 |
| Y3 | Y8 | Yellow | .880 | .385 |

Dimensional Specs

inches [millimeters]

BAT TOGGLE

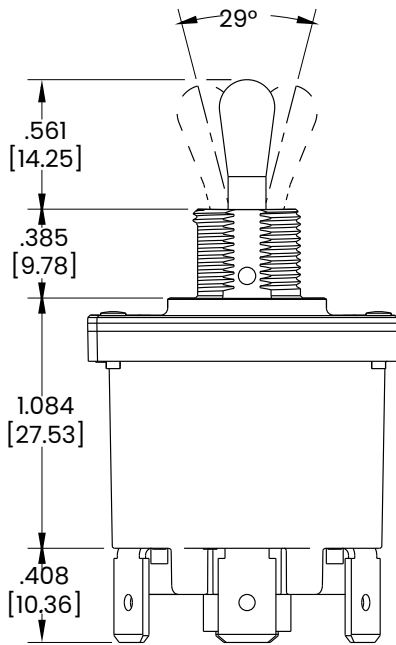

TALL BAT TOGGLE

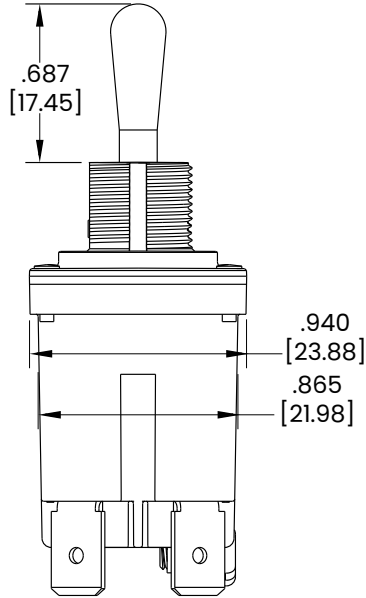

PADDLE TOGGLE

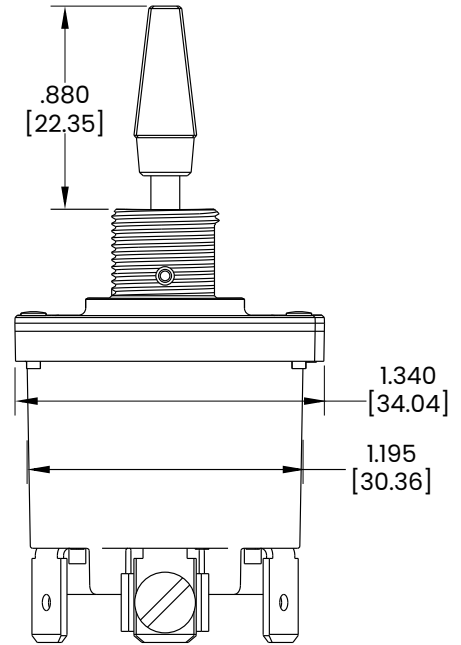

TERMINALS

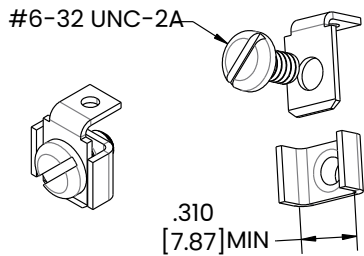

SCREW (AND CAGE) TERMINAL

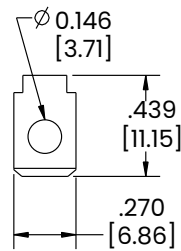

.250 TAB(Q.C.) TERMINAL

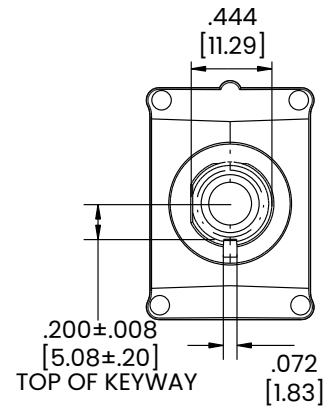
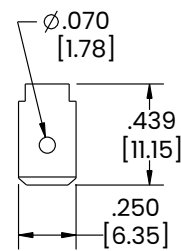

PANEL CUTOUTS

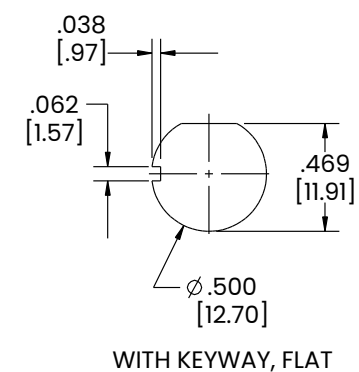
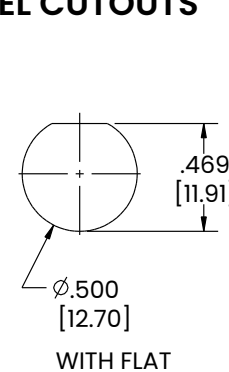
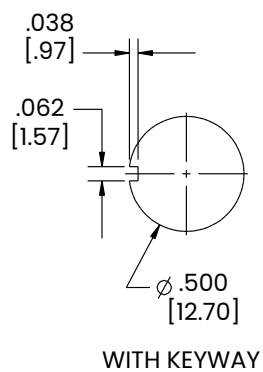
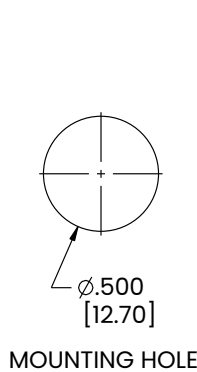

Authorized Sales Representatives and Distributors

Click on a region of the map below to find your local representatives and distributors or visit www.carlingtech.com/findarep.



About Carling

Founded in 1920, Carling Technologies is a leading manufacturer of electrical and electronic switches and assemblies, circuit breakers, electronic controls, power distribution units, and multiplexed power distribution systems. With six ISO9001 and IATF16949 registered manufacturing facilities and technical sales offices worldwide, Carling Technologies Sales, Service and Engineering teams do much more than manufacture electrical components, they engineer powerful solutions! To learn more about Carling please visit www.carlingtech.com/company-profile.

To view all of Carling's environmental, quality, health & safety certifications please visit www.carlingtech.com/environmental-certifications.

© Carling Technologies, Inc.

6. Carling is a registered trademark of Carling Technologies, Inc. in the U.S. and other countries.